

TECH SHEET

# Climacondens® high

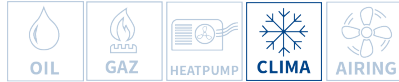

Condensate disappears quietly from office and living space

The Climacondens® high impresses with its compact design. The maximum delivery height of 7 m with a delivery rate of up to 5 l/h makes the Climacondens® high a versatile all-rounder.



Very quiet running noise: 19 dB(A) at 1m distance



Low maintenance and durable thanks to innovative condensate sensors

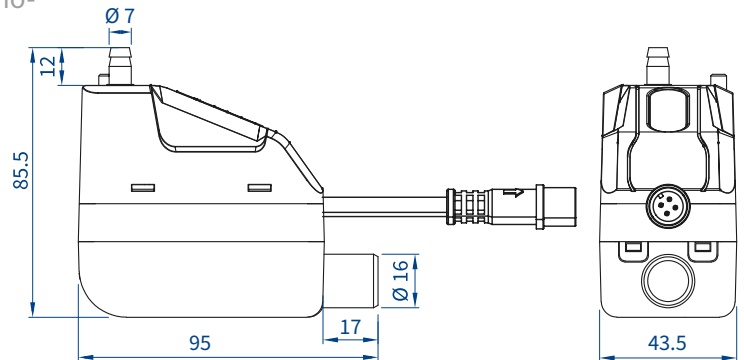

### Technical data

Article number Climacondens®flat	1001839.B
Max. recommended delivery head	7 m
max. delivery capacity at a delivery head of 7 m	5 l/h
max. intake height	1.5 m
Noise level at 1 m	19 dB(A)
Power supply	230 V / 50 Hz
max. connected load	12 W
max. condensate temperature	50° C
Alarm contact	NC, 3.0 A
IP protection	IP 21
Tank volume	45 ml
Net weight	0.15 kg

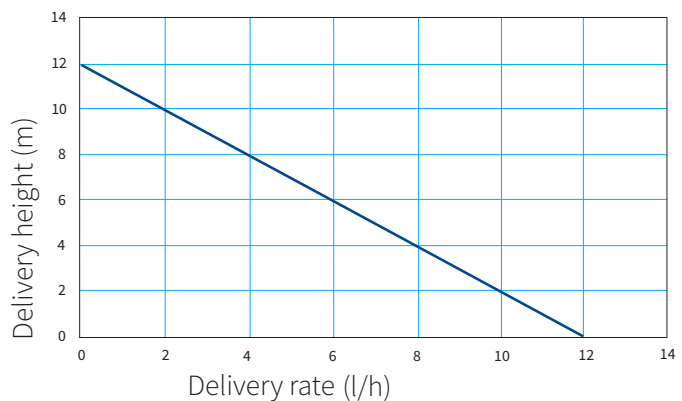

### Scope of delivery

Climacondens®high pump incl. tank
Hard-wired mains/alarm cable 1.5 m
Silicone cover as vibration damper (1 pc.)
Fixing set with metal bracket, Velcro fastener (2 pcs.), dowels (2 pcs.), screws (2 pcs.)
Inlet adapter (1 pc.)
Condensate inlet connection: Condensate inlet pipe (100 mm), cable ties (4 pcs.)
Condensate drain connection: Condensate drain PVC hose (150 mm), cable ties (2 pcs.)

### Recommended accessories

Hose condensate inlet ø 16mm (5 m)	1001976.A
Hose condensate drain ø 6mm (10 m)	1001974.A
Hose condensate drain ø 6mm (20 m)	1001975.A
Hose clamp Condensate inlet	1000056.A
Condensate drain hose clamp	1000055.A